

GET OFF TO A
GOOD START
WITH A...



- helmets & accessories
- apparel
- accessories
- carriers & racks
- bumpers & winches
- plows & implements
- frame & chassis
- utv accessories
- body
- handlebar
- cables & levers
- engine
- fuel & intake
- electrical & ignition
- clutch
- drive
- bearings
- brakes
- suspension & steering
- tires & wheels
- chemicals
- tools
- go cart
- trailer accessories

Max-Torque clutches are designed, engineered and manufactured to deliver exceptional performance. They are unique and original in design and engineering.

SMOOTHER • LESS FRICTION • EXTENDED LIFE • EFFICIENT

PARTIAL CLUTCH BREAK DOWN

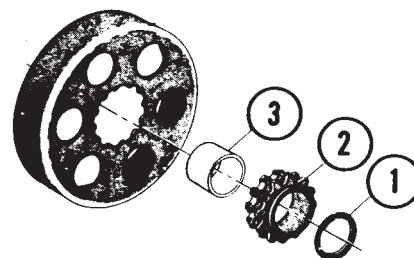

SHAFT SNAP RING

Sold each • (Reference #1)

MT450 0.75

3/4" Clutch

MT452 0.75

5/8" Clutch



"SS" SPROCKET CLUTCHES

With 3/16" keyway. Two set screw holes 90 degrees apart - tapped 1/4-28.

| PART # | | BORE | TEETH | CHAIN | PITCH |
|--------|--------------|------|-------|-------|-------|
| MT1234 | 38.99 | 3/4" | 12T | #35 | 3/8" |
| MT1258 | 38.99 | 5/8" | 12T | #35 | 3/8" |
| MT1034 | 38.99 | 3/4" | 10T | #41 | 1/2" |
| MT1058 | 38.99 | 5/8" | 10T | #41 | 1/2" |
| MT1158 | 38.99 | 5/8" | 11T | #35 | 3/8" |
| MT1334 | 38.99 | 3/4" | 13T | #35 | 3/8" |



SET SCREW FOR MAX-TORQUE CLUTCH

Set Screw (1/4") • Sold Each (Minimum 10)

MT119 0.25



MAX-TORQUE PULLEY CLUTCHES

Pulley has a 3.20" O.D. and the clutch drum is 4.2" O.D.

| PART # | | BORE |
|---------|--------------|------|
| MT32034 | 55.99 | 3/4" |
| MT32058 | 55.99 | 5/8" |



CENTRIFUGAL CLUTCH KEY

3/16" x 3/4" • Sold Each (Minimum 10)

MT445 0.40



BRONZE BUSHING BEARINGS

Reference #3

MT455 2.55

For 3/4" Clutch (7/8" ID)

MT456 2.55

For 5/8" Clutch (3/4" ID)



SPROCKETS

Including Bronze Bushings • Reference #2

MT462 14.10

For 5/8" clutch, 35 Chain, 11 Tooth

MT463 14.10

For 3/4" clutch, 35 Chain, 12 Tooth

MT465 12.90

For 3/4" clutch, 35 Chain, 13 Tooth

MT468 12.90

For 3/4" clutch, 41 Chain, 10 Tooth

MT469 12.90

For 5/8" clutch, 41 Chain, 10 Tooth





AUTOMATIC CENTRIFUGAL CLUTCHES

4 Cycle Bikes • Arctic Kitty Cat
Single Sprocket Self-Contained Clutches

SINGLE SPROCKET SELF CONTAINED

Popularity of these four models allows greater production economics without sacrifice of quality and we pass these savings on to you. The 400 Series clutches have more contact surface than most competitors. The 400 Series clutch has built-in staying power. Almost 3-3/4 square inches of steel friction material engagement shoe surface assures positive pulling power as long as the R.P.M. is in full contact range. There's no slipping when you need the "go-power". The 400 Series clutches have continued performance even when they were partly destroyed in torture tests. Bearings have been almost completely worn through by sand and the 400 Series continued to function.

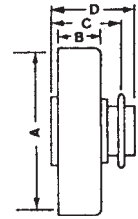

- helmets & accessories
- apparel
- accessories
- carriers & racks
- bumpers & winches
- plows & implements
- frame & chassis
- utv accessories
- body
- handlebar
- cables & levers
- engine
- fuel & intake
- electrical & ignition
- clutch
- drive
- bearings
- brakes
- suspension & steering
- tires & wheels
- chemicals
- tools
- go cart
- trailer accessories



CSC
400
SERIES
Engines to 5 HP

| PART # | | TYPE | TEETH | BORE | CHAIN | A | B | C | D |
|--------|-------|--------------|-------|------|-------|----|----|------|------|
| 211627 | 55.29 | CSC* | 12 | 5/8 | 35 | 4" | 1" | 1.74 | 2.22 |
| 209760 | 39.65 | CSC* | 12 | 3/4 | 35 | 4" | 1" | 1.74 | 2.22 |
| 209768 | 42.15 | CSC* | 10 | 3/4 | 40/41 | 4" | 1" | 1.77 | 2.22 |
| 217636 | 55.95 | ** E-Z Rider | 12 | 3/4 | 35 | 4" | 1" | 1.74 | 2.22 |
| 217633 | 55.95 | ** E-Z Rider | 10 | 3/4 | 40/41 | 4" | 1" | 1.74 | 2.22 |

*COMET SELF CONTAINED

**MAINTENANCE FREE - ONE YEAR LIMITED WARRANTY

SC
400
SERIES
Engines to 7 HP

SINGLE SPROCKET SELF CONTAINED

The 400 Series clutch is durable. Designed and built for direct drive mini-bikes, one of the most rugged applications of a modestly-priced automatic centrifugal clutch. Having extra ability for rough service, 400 Series Clutches are known to stand up better when the going gets rough. Sand, grit, gravel and dirt are taken in stride with the 400 Series clutch. Operates under conditions that would destroy most clutches.

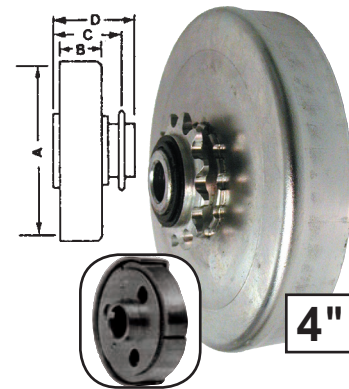

| PART # | | TEETH | BORE | CHAIN | A | B | C | D |
|--------|-------|-------|------|-------|----|----|------|------|
| 216471 | 98.75 | 13 | 3/4" | 35 | 4" | 1" | 1.45 | 2.33 |

400 SERIES - AUTO CENTRIFUGAL CLUTCHES

SINGLE SPROCKET / TWIN SPROCKET

Use the 400 Series for 4 cycle engines only to 8 H.P. "Straight Centrifugal" rotor action provides slipping range into smooth, non-aggressive engagement with operational RPM's of approximately 2,000 through 3,500. Ideal for high-inertia applications such as mini-bikes, go-karts, etc. Ease of installation and maintenance makes the 400 Series clutch a favorite with thousands of mini-bikers and others who have tough service application requirements.

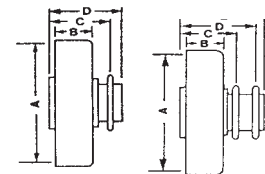

400
SERIES
Engines to 8 HP

| PART # | | TEETH | KEYWAY | BORE | PITCH | A | B | C | D |
|--------|--------|-------|--------|------|-------|----|----|------|------|
| 203963 | 105.55 | 11 | 3/16 | 3/4 | 35 | 4" | 1" | 1.73 | 2.04 |

BRAKE SYSTEMS

| BAND ONLY PART # | | SPECIFICATIONS | | | | |
|------------------|-------|----------------|-------|-----|-----|----------|
| | | A* | B | C | D | E |
| 10945 | 21.95 | 2-1/2 | 1-1/2 | 3/8 | 3/4 | 1/8 Slot |

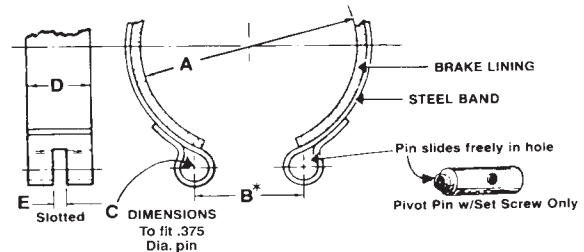

*NOTE: This is a reference dimension with band locked in position around "A" diameter of drum.

BRAKE BAND

Brake band for our 485 brake drum
Does not come with pin
Sold each



486 14.95



GO CART

MODEL 20 / 30 SERIES TORQUE CONVERTER SYSTEM

USE ON ALL ENGINES THRU 7HP / SOME APPLICATIONS TO 8HP

20 SERIES

Symmetrical

| PART # | DESCRIPTION |
|----------------------|----------------|
| 219560 121.58 | Driver 1" Bore |

30 SERIES

Asymmetrical

| PART # | DESCRIPTION |
|----------------------|----------------------------|
| 219465 105.85 | Driven 3/4" Bore x 6" Dia. |

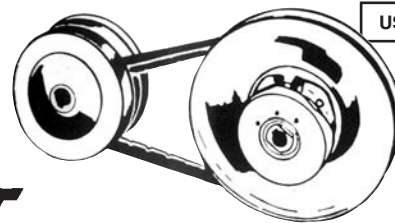

USES 3/4" BELT



DRIVE BELTS FOR 20/30 SERIES UNITS

6" & 7" DIAMETER UNITS • 3/4" TOP WIDTH



FOR PARTS BREAKDOWN OR SHEETS FOR INFORMATION - CONTACT OUR OFFICE

| SYMMETRICAL PART # | MARKED ON BELT | 6" DIAMETER DRIVEN | 7" DIAMETER DRIVEN | OUTSIDE DIAMETER | ASYMMETRICAL PART # | MARKED ON BELT |
|--------------------|----------------|--------------------|--------------------|------------------|---------------------|----------------|
| ---- | 884-70 | 6-15/16 - 7 | No Fit | 27.36 | 203589 | 994-70 |

COMET'S TORQ-A-VERTER KIT

FOR MINI-BIKES & GO CARTS USING 4 CYCLE ENGINES

- Converts direct drives into high performance fun machines in minutes
- No welding
- No misalignment
- No guesswork
- No adjusting of belt centers
- Just bolt on the Torq-A-Verter and take off!
- This kit includes 1 each: mounting bracket with sprocket, 1 bag of hardware, driver, belt, cover

RECOMMENDED TO 8 HP MAXIMUM

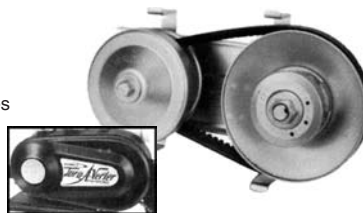

SPROCKETS FOR TORQ-A-VERTER

10 Tooth, 5/8" Bore, 1/2" Pitch. Replacement sprocket for Torq-A-Verter. 41/40 chain.

202 **29.90**

12 Tooth, 5/8" Bore, 1/2" Pitch. Replacement sprocket for Torq-A-Verter. 35 chain

200379 **22.80**

IMPORTANT!

Torque Converter DRIVE UNIT MUST NOT FLOAT on engine crankshaft. It must be bolted tight against engine crankshaft shoulder. Recommended torque for bolt: 24 ft. lbs. to 30 ft. lbs. max.

| PART # | CRANKSHAFT SIZE | # OF TEETH | CHAIN SIZE | REPLACE BELT |
|----------------------|-----------------|------------|------------|--------------|
| 218353 242.99 | 3/4" | 10 T | #40-41 | 203589 |



MANCO TO COMET CROSS REFERENCE

| MANCO NO. | COMET # | MANCO NO. | COMET # |
|-----------|---------|-----------|---------|
| 1154 | 200393A | 5959 | 203589A |
| 2433 | 203783A | 6814 | 203784A |
| 2795 | 203588A | 9659 | 203590A |
| 3619 | 203792A | 8192 | 203593A |
| 4292 | 203580A | | |



COMET DRIVE SYSTEM CONVERSION FOR THE HONDA ODYSSEY

This system completely converts your original torque converter drive system and features simplicity, ruggedness and lasting performance. This is a great system for the occasional racer and the person weary of constant drive system maintenance and expense.

All components of this conversion kit are ready to "bolt-on". Kit includes 94C - 209234 drive clutch, 209451 belt and 90D - 212371 driven "T.C." (readily accepts transfer of Odyssey brake disc). 94C calibration: 6 pucks 206143 and white spring - 205820.

FOR COMPLETE PARTS LIST - CALL OUR OFFICE



APPROXIMATE ENGAGEMENT 4600 RPMs



94C CLUTCH - 90D DRIVEN 209187 **483.70** 1-1/4" Wide Belt FL250 Only

TIPS FOR PROPER BELT ADJUSTMENT USING 6" OR 7" DRIVEN UNITS



1. Select belt for nearest approx. shaft setting. 2. Check belt tension. Belt should be at its highest point in the driven pulley flanges. Remove outer half of driven clutch. Squeeze belt down and pull forward as shown. Position engine so that 1/8" to 3/16" of clearance is provided around clutch bushing/hub. NOTE: By increasing the spring tension of the torque system...the power ratio of the system (driver and drive) is held longer at higher engine rpm's before it is overcome by driver. To shorten the time required for the driven member to attain ratio, DECREASE the amount of spring tension of the torque cams. This will allow the rpm of the drive clutch to move power ratio of the driven unit at a faster rate in a lower rpm.

DRIVE BELTS FOR T.C. 88/C.A.T. 99 SERIES UNITS

6" & 7" DIAMETER UNITS • 5/8" TOP WIDTH



| T.C. 88 SERIES PART # | MARKED ON BELT | 6" DIAMETER DRIVEN | 7" DIAMETER DRIVEN | OUTSIDE DIAMETER | C.A.T. 99 SERIES PART # | MARKED ON BELT |
|-----------------------|----------------|--------------------|--------------------|------------------|-------------------------|----------------|
| 200423 28.95 | 883-90 | 8-11/16 - 8-3/4 | 7-3/4 - 7-13/16 | 31-15/64 | ---- | 993-90 |

DISC CALIPER BRAKE

This brake can be used on snowmobiles, go-karts, mini-bikes, garden tractors and numerous industrial applications. The brake has 1.9 square inches of replaceable automotive brake material and can be set in 8 different lever positions and pulled from either direction. Caliper and disc must be ordered separately.

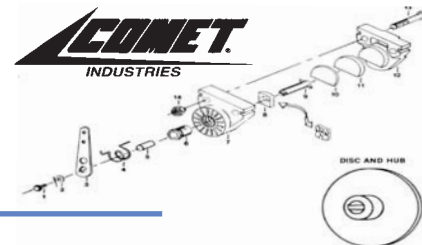

| PART # | DISC & HUB |
|---------------------|--|
| 212369 40.05 | 6-3/8" dia., 1" bore, 1/4" keyway with set screw |
| 212396 56.20 | 10" dia., 1" bore, 1/4" keyway with set screw |

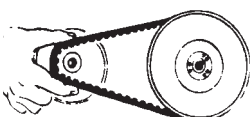

MINI BIKE THROTTLE CONTROLS

Twist Grip • Metal
Deluxe throttle controls which come complete with twist grip and dummy grip.

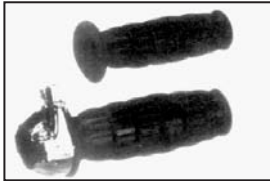

257 7/8" Tubing **22.95**

BRAKE-THROTTLE CABLE

UNIVERSAL • 100" INNER CABLE • 92" CASING • 3/16" BARREL
• This universal cable has an extra length for some snowmobiles, atvs, go carts and mini bikes
• Comes complete with outer casing



269 **6.75**

MINI BIKE / UNIVERSAL THROTTLE CABLES

This cable comes complete with inner cable and housing. It also has a ball on one end, barrel on the other.



261 48" inner / 43" casing 3/16" Barrel **2.60**
262 53" inner / 48" casing 3/16" Barrel **2.70**
263 60" inner / 55" casing 1/4" Barrel **2.95**

WIRE STOP

Wire Stop. Used for securing inner wire to engine. Sold each.



LP05902 **0.95**

MINI BIKE WIRE SWIVEL STOP

This universal wire stop will work on throttles and brake cables. It will also work as a wire swivel.



267 **0.95**

MINI-BIKE BRAKE CABLE

UNIVERSAL • 65" INNER CABLE • 60" CASING • 3/16" BARREL
• This is a universal cable
• Heavy duty for long wear
• Comes complete with outer casing



264 **2.90**

IMPORTED INDUSTRIAL RIVETED ROLLER CHAIN AND LINKS

ROLLER CHAIN

Sold in 10' or 100' lengths only



| 10' Length | | | 100' Length | | |
|------------|------|--------------|--------------|---------|---------------|
| CHN25 | #25 | 25.80 | 1/4" x 1/8" | ---- | |
| CHN35 | #35 | 21.60 | 3/8" x 3/16" | CHN3510 | 210.00 |
| CHN40 | #40 | 24.75 | 1/2" x 5/16" | CHN4010 | 235.00 |
| CHN41 | #41 | 16.90 | 1/2" x 1/4" | CHN4110 | 164.40 |
| CHN42 | #42 | 19.75 | 1/2" x 3/16" | ---- | |
| CHN43 | #43 | 16.10 | 1/2" x 1/8" | ---- | |
| CHN50 | #50 | 38.80 | 5/8" x 3/8" | ---- | |
| CHN60 | #60 | 49.05 | 3/4" x 1/2" | ---- | |
| CHN420 | #420 | 35.60 | 1/2" x 44" | ---- | |
| CHN428 | #428 | 42.95 | 1/2" x 5/16" | ---- | |

CONNECTING/OFFSET LINKS

Sold each



| Connecting Link | | | Offset Link | | |
|-----------------|-------------|----------|-------------|-------------|--|
| CCL25 | 0.65 | #25 sgl | OSL25 | 1.25 | |
| CCL35 | 0.60 | #35 sgl | OSL35 | 1.10 | |
| CCL40 | 0.55 | #40 sgl | OSL40 | 1.10 | |
| CCL41 | 0.55 | #41 sgl | OSL41 | 1.15 | |
| CCL42 | 0.65 | #42 sgl | OSL42 | 1.35 | |
| CCL43 | 0.65 | #43 sgl | OSL43 | 1.15 | |
| CCL50 | 0.95 | #50 sgl | OSL50 | 1.65 | |
| CCL60 | 1.25 | #60 sgl | OSL60 | 2.00 | |
| CCL420 | 1.00 | #420 sgl | OSL420 | 1.85 | |
| CCL428 | 1.00 | #428 sgl | OSL428 | 1.85 | |

NICKEL PLATED ROLLER CHAIN LINKS

Sold each

OFFSET LINK DESC. **1.50**
02-396 #41 sgl.



QUAD STAKE RIVET KIT

• The perfect compliment to the 678135 Jumbo Chain Tool (below) • Retain that factory Quad stake look • Safely and properly peens soft-nose-type masterlink pin tip.



678142 **22.70**

JUMBO CHAIN TOOL

• Designed to break and / or rivet roller chain • Masterlink sideplate press kit included • Fits all 520, 525, 530, 630 standard or O-ring type chain • Will also service industrial chain from #50 through #80 • Screws and attachments are made from 86L20 steel and then heat treated for strength and durability • The extractor pin is firmly guided by a removable guide, ensuring long pin life • May be bolted to a workbench, supported in a vise or held by the handle • When bolted to a solid surface, air or electric wrenches may be used to break chain • Recommended for heavy duty use.

JUMBO CHAIN TOOL **678135 140.00**
REPLACEMENT PIN **678135D 8.70**



- helmets & accessories
- apparel
- accessories
- carriers & racks
- bumpers & winches
- plows & implements
- frame & chassis
- utv accessories
- body
- handlebar
- cables & levers
- engine
- fuel & intake
- electrical & ignition
- clutch
- drive
- bearings
- brakes
- suspension & steering
- tires & wheels
- chemicals
- tools
- go cart
- trailer accessories

GO CART



CHAIN DETACHER

A handy tool to remove and replace pins in chain links - lightweight - heat treated.



| | | |
|----------------------|------|-------|
| CHAIN DETACHER | 1733 | 17.75 |
| REPLACEMENT PIN ONLY | 1729 | 2.40 |

helmets & accessories

apparel

accessories

carriers & racks

bumpers & winches

CHAIN BREAKER

• For 420 to 630 chain • Will push link pin completely through link • Handle folds away for easy storage • Replaceable pin is heat treated for strength and wear resistance.



| | | |
|---------------|--------|-------|
| CHAIN BREAKER | 678001 | 26.00 |
| PIN ONLY | 678002 | 3.85 |

plows & implements

frame & chassis

utv accessories

body

CHAIN PRESS TOOL KIT

• Fits 520 - 530 standard and O-ring chains.



| | | |
|----------------------|--------|-------|
| CHAIN PRESS TOOL KIT | 678066 | 52.00 |
| PRESS PLATES ONLY | 678067 | 13.75 |

handlebar

cables & levers

engine

fuel & intake

electrical & ignition

clutch

drive

TUBE TYPE KART SLICK TIRES • IMPORTED

| PART # | SIZE | PLY RATING | TREAD | RIM WIDTH | O.D. | WIDTH | PSI | |
|--------|-----------|------------|-------|-----------|-------|-------|-----|------|
| 693403 | 410/350-4 | 4 | Slick | 2-3/4" | 10.5" | 3.5" | 20# | 5.50 |

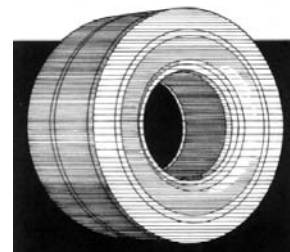

bearings

KART WHEELS

Air Tires - 2 Piece Split Rim - 14 Gauge
4 Hole - 2 13/16" Bolt Circle - 2" Center Hole (5/16" Bolt Hole)
NON-HIGHWAY SERVICE (NHS)

| PART # | RIM DIA. | WIDTH | FITS TIRE SIZE | |
|--------|----------|--------|----------------|------|
| 690800 | 4" | 2-1/8" | 280-4 | 7.50 |
| 690801 | 4" | 2-3/4" | 410-4 | 7.50 |
| 690802 | 5" | 2-3/4" | 350-5; 410-5 | 9.50 |
| 690803 | 6" | ----- | ----- | 9.50 |

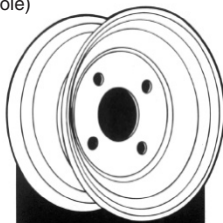

HEAVY DUTY INDUSTRIAL BEARING

Sold each

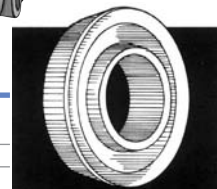
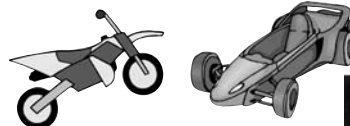

| PART # | ID | OD | OL | |
|--------|------|--------|-------|------|
| 325 | 1/2" | 1-3/8" | 7/16" | 1.85 |
| 326 | 5/8" | 1-3/8" | 7/16" | 1.70 |
| 327 | 3/4" | 1-3/8" | 7/16" | 1.70 |

suspension & steering

tires & wheels

chemicals

tools

go cart

trailer accessories

AEROSOL CHAIN SPRAY

Excellent with rubber 'o-ring' chain sprays. Upside down or right side up. Cleans, lubricates and protects. Use for competition or touring.



KL605 9.70 Sold each 16 oz.

